

APPROACH PLAN

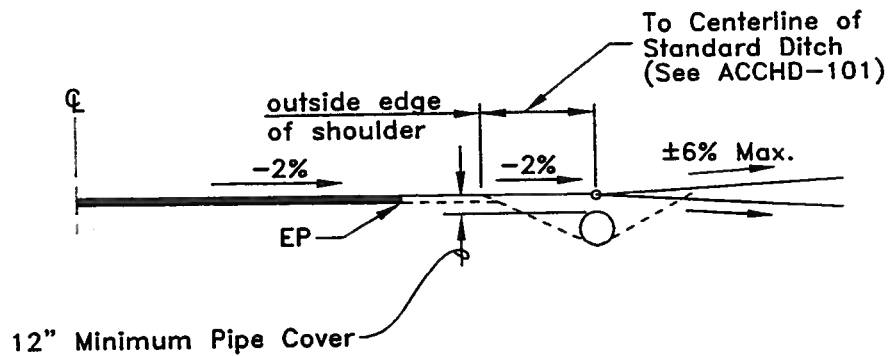

GRADE REQUIREMENTS

APPROACH TABLE

APPROACH TYPE	Appr. Width		Min. Radius
	Min.	Max.	
Farmyard, Field	20'	40'	20'
Residential*, on Rural Road	20'	30'	10'
Residential*, on Subd. Road	20'	36'	0'
Or	15'		5'

APPROACH STRUCTURAL SECTION

2.5" Asphalt (optional)
6" Base
9" Sub Base

*Residential approach serving 1 or 2 residences.
See ACCHD-106 for approaches serving commercial, or 3 or more residences.

NOTES:

1. APPROACH SPACING SHALL CONFORM TO SECTION 3000 OF THE ACCHD MANUAL.
2. INGRESS/EGRESS BY FORWARD MOTION ONLY.
3. CULVERT PIPE SHALL BE 12" MIN. DIAMETER. CULVERT PIPE SHALL EXTEND TO THE INTERSECTION OF THE DITCH LINE AND THE 4:1 APPROACH FORESLOPE. PIPE MATERIAL SHALL BE EITHER 0.064" THICK CORRUGATED STEEL, 0.060" CORRUGATED ALUMINUM OR CLASS V REINFORCED CONCRETE.
4. SUBDIVISION ROADS ARE DEFINED AS ROADS THAT PRIMARILY PROVIDE ACCESS TO ADJACENT LOTS OR PARCEL, DO NOT SERVE AS COLLECTOR ROADS, ARE NOT LOCATED ON SECTION OR QUARTER SECTION LINES, AND HAVE A POSTED SPEED OF 25 MPH OR LESS. ALL OTHER ROADS SHALL BE CONSIDERED RURAL ROADS FOR APPLICATION OF APPROACH STANDARDS.

STANDARD RESIDENTIAL APPROACHES
N.T.S.

STANDARD DRAWING No. ACCHD-105
CANYON COUNTY HIGHWAY DISTRICTS
CANYON COUNTY, IDAHO

REVISED 5/07